

Sensedge Duct

(Wired Model)

Installation and Setup Guide

1. Important Safeguards

Please read the safety warnings before use and take the necessary precautions to reduce the risk of fire, electric shock, or injury. The Kaiterra limited warranty applies only if the unit is used according to these instructions. Kaiterra will not be liable for any damages, injuries, or losses resulting from use of the product that does not comply with these instructions or the safety warnings provided.

Warning

- To reduce safety risks, always use service personnel from the manufacturer or service provider, or other qualified personnel for installation and maintenance.
- Make sure the power is OFF during installation or maintenance.
- DO NOT tamper with or use non-official spare parts for repair or maintenance.
- DO NOT use the device in environments with high humidity or possible direct exposure to water.
- DO NOT use the device near heat sources such as radiators, furnaces, ovens, or stoves.

What's Included

Parts and Tools You Will Need for Installation

Parts (Included in the Packaging)



Sensedge Mini



Sensedge Mini
sensor modules x 2



In-duct kit



Surface/drywall
mount



PoE connector



Drill assist
sticker



Mounting
brackets x 4



Tapping screws
(M4 x 10mm) X 4



Tapping screws
(M4 x 20mm) X 4



USB-C adaptor



Large washer x 4



Small washer x 4



Large seal plug x 2



Small seal plug x 4



Cable grommet



USB cable



Charger

Tools (Not included in the packaging)



Cross screwdriver



Power drill



35 mm Carbide-tipped hole saw



2.5mm (3/32") Drill bit

2. Pre-installation Review

Before You Begin

Ensure you have the following before starting the device installation:

- **Kaiterra Data Platform Account:** If you don't have an account or need help, please contact your Customer Success Manager at Kaiterra, or email us at support@kaiterra.com.
- **Kaiterra Configuration App:** A smartphone with the latest version of the app installed. Search for "Kaiterra" in the Apple App Store or Google Play Store to download.
- Review all proposed device locations with your **Customer Success Manager** to confirm that all installation locations are project-suitable.
- Devices are to be installed directly onto a **supply or return air duct**.

Optimal Device Installation Location

For measuring air quality in the supply or return duct:

- For supply air measurement, install the **Sensedge Duct in the supply duct** downstream of filtration and mixing.
- For return air measurement, when a dedicated return duct is available, install the **Sensedge Duct in the return duct**. When the system uses an unducted return, install an indoor air quality monitor such as a **Sensedge Mini** on a wall within the return air zone. A Sensedge Duct is not required.

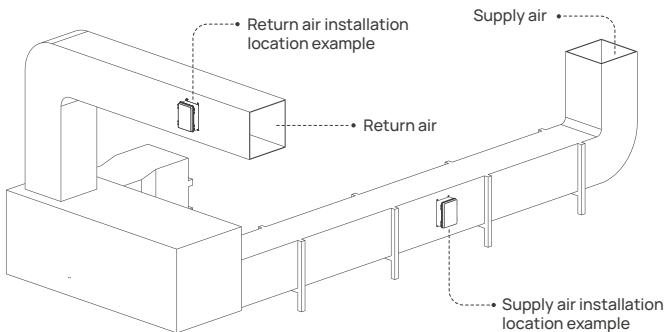

For measuring air quality in the outdoor air intake:

- For outdoor air intake measurement, install a **Sensedge Duct in the outdoor air intake duct** where only outdoor air is present, typically between the weather louver and the mixing box, downstream of the louver and upstream of any mixing with return air.

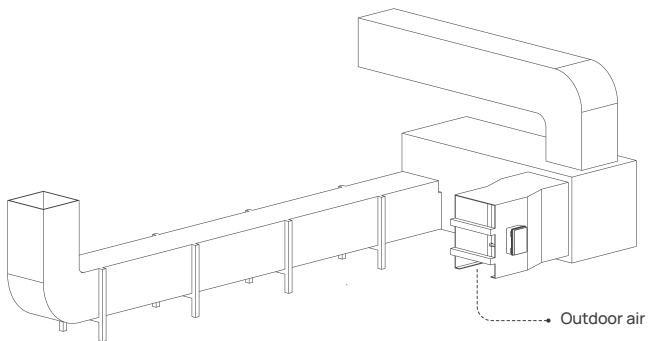

3. Know Your Device

Remove the front cover of the Sensedge Mini, and you will find the ON/OFF switch and RESET pinhole, as well as a device status light.

The Sensedge Mini draws air in from the lower side and releases it from the upper side. It is essential to keep both sides unobstructed, as any disruption to the airflow can impact the device's readings and accuracy.

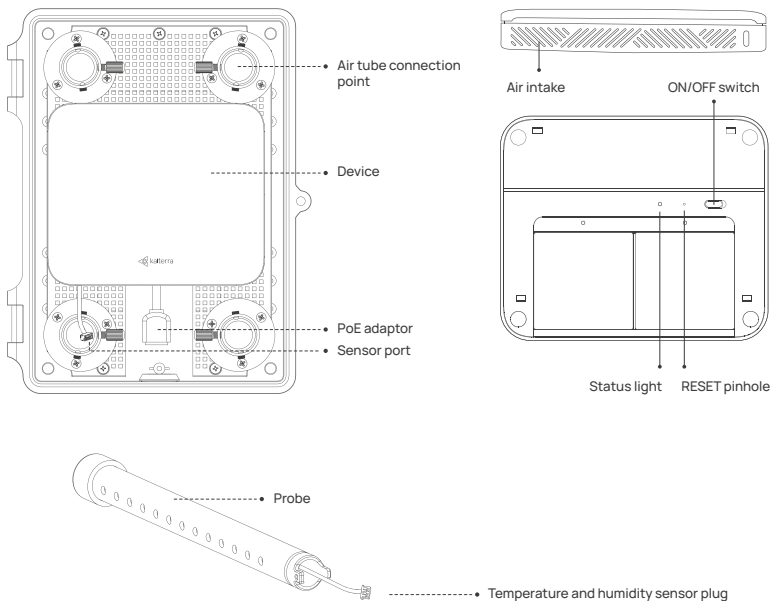

4. Sensor Modules

To install the sensor module, simply align it with the bay and press it in, ensuring the Kaiterra logo on the plastic tab is facing outwards. When inserted correctly, the module will click into place, and an LED light above the bay will briefly flash red if the device is powered on.

Sensor modules may be inserted in either sensor bay, and in any order. After successfully installing the modules, put the front cover on.

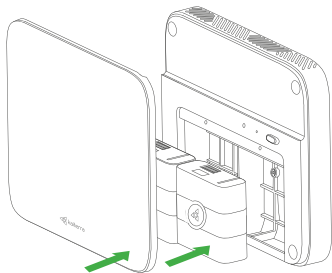

Pull the tab around the sensor module and remove the module straight out, keeping it parallel to the device.

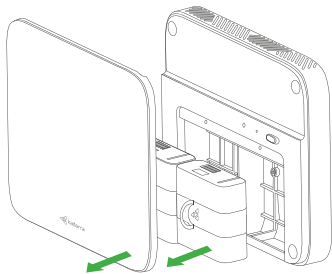

5. Installation Steps

1 Select the installation location

- Choose a straight, vertical section of the duct to mount the monitor.
- Ensure at least 5 feet (1.5 meters) of straight, unobstructed ductwork upstream of the sensor for accurate airflow measurement.

2 Identify the airflow direction

ⓘ Important! Air should only enter the kit through one of the lower ports and exit through the opposite upper port.

3 Apply the drilling template

- Identify the correct holes to drill on the template sticker according to your installation setup. Select either Group A or Group B only.
- Position the template sticker on the duct, making sure it is level and aligned perpendicular to the airflow direction.

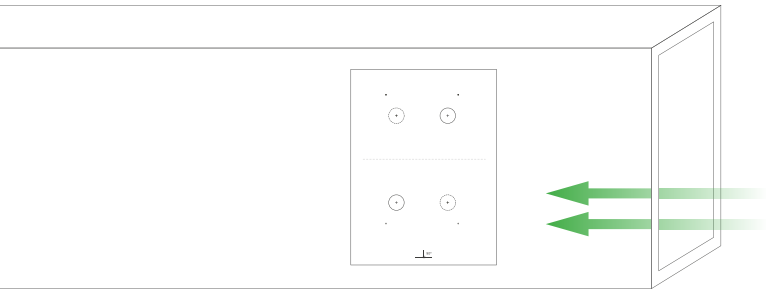

4 Drill holes

- Use the drill bit sizes indicated on the template to create the required openings.
- Drill only the holes identified earlier.

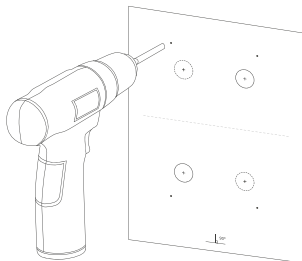

5 Assemble the duct kit

- Secure the mounting brackets to the rear of the in-duct housing using the 10mm tapping screws.

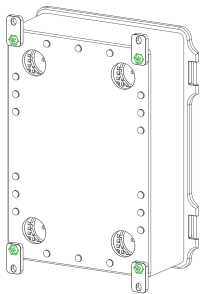

- Place two O-rings on each probe.



- c. Insert the probe with the T/H sensor into the lower port, and the other probe into the upper port.

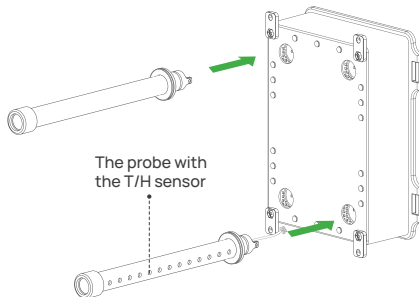

- d. Cover the remaining two holes using the stoppers.

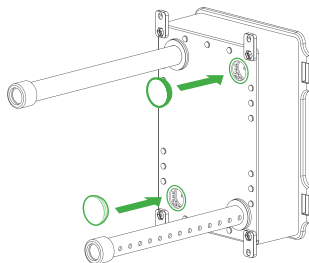

- e. Push the probes from the back of the kit until you hear a click, confirming they are securely seated at the correct depth.

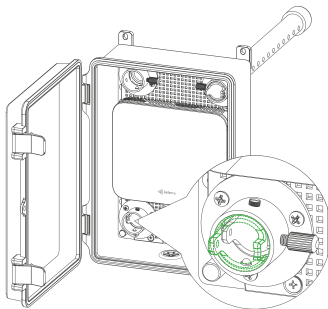

6 Secure the monitor assembly to the ductwork

- a. Install the Sensedge Duct onto the ductwork, secure using the tapping screws. Place a washer between the bracket and the duct wall.
- b. Make sure the O-ring forms a complete seal, covering any gaps between the Sensedge Duct and the ductwork.

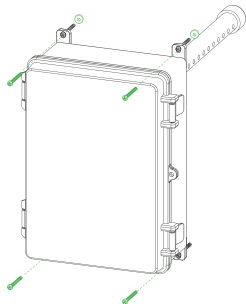

7 Securing the probes

- a. Adjust the angle of the probe by rotating it. Use the orange markings at the end of the probe to confirm correct alignment. Note: The end of the finger grip with the small hole indicates where the sensing holes are located inside the duct.
- b. Ensure the holes on the lower air-in probe are aligned parallel to and facing directly into the airflow. Position the holes on the air-out probe so they face away from the airflow and remain parallel to the airflow direction.

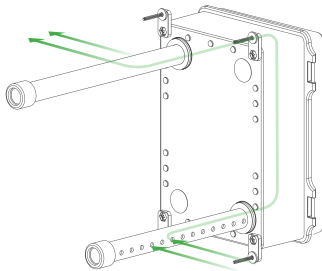
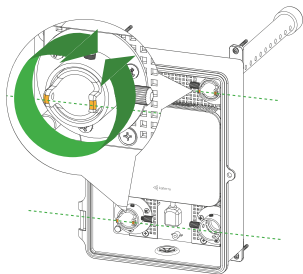

- c. Tighten the knob on the side to lock the probes in position. Tighten just enough to prevent movement, but avoid over-tightening, as excessive force may deform the probes.

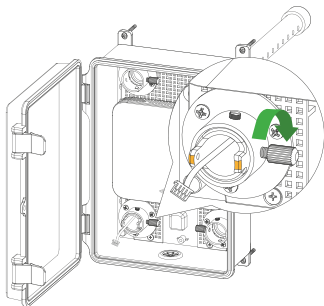

8 Power the device

The device can be powered using an Ethernet cable connected to a PoE adaptor, a USB-C cable, or a 4-pin Phoenix connector.

a. PoE

Route the Ethernet cable through the port opening at the bottom of the box and connect it to the PoE adaptor.

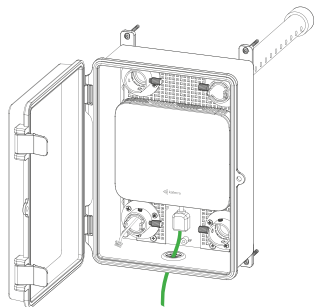

b. USB-C

Route the USB-C cable through the port opening at the bottom of the box and connect it to the USB-C power adaptor.

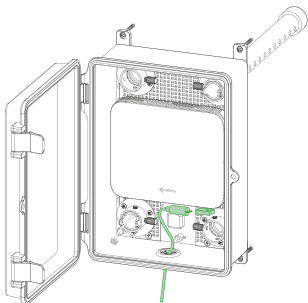

c. 4-pin Phoenix connector

- Remove the device by rotating it anti-clockwise.
- Route the 4-pin Phoenix connector through the port opening at the bottom of the box and plug it into the back of the Sensedge Mini.
- Mount the Sensedge Mini onto the backplate, align the three protrusions on the back of the device with the corresponding slots, then gently rotate the device to lock it in place.

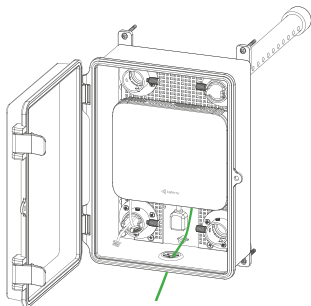
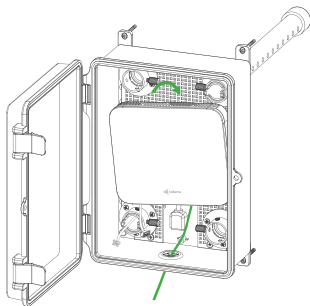
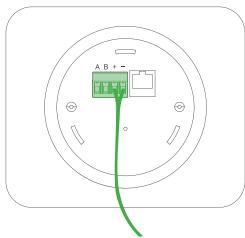

9 Connect the external T/H sensor

Connect the cable extending from the probe to the corresponding port on the device.

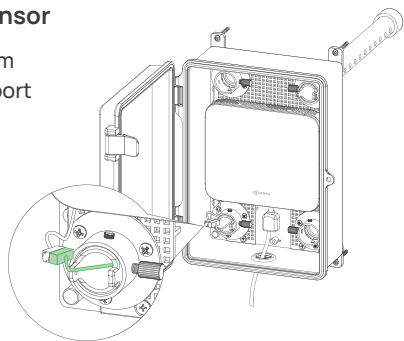

10 Power on the monitor

- Remove the front cover of the Senseedge Mini. Locate the ON/OFF switch above the sensor bays and turn the device on. The STATUS light next to the switch will briefly illuminate if power is present.
- Replace the front cover and follow the instructions below to complete the setup.

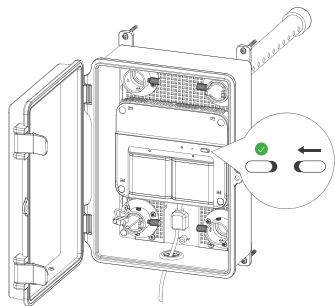

11 Complete setup

Once the installation and setup are complete, close the front cover and secure it using the two snap locks on the sides.

6. Network Connectivity

Connectivity Diagram

On each floor:

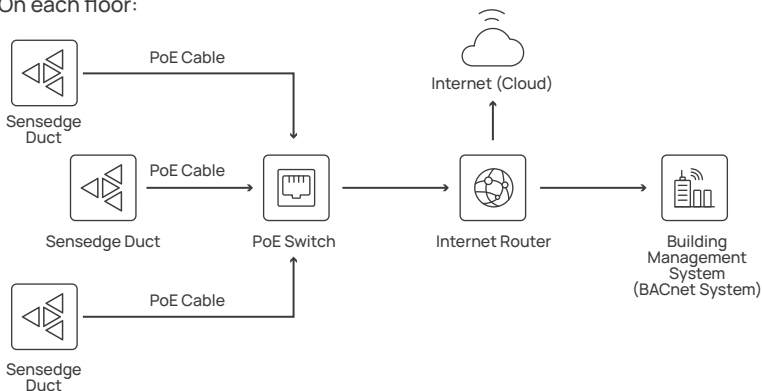

Firewall Configuration

mqtt.kaiterra.com Port 8884

api.kaiterra.com Port 443

dl.kaiterra.com Ports 80 and 443

time.kaiterra.com Port 123

1. The Sensedge Duct connects physically to a PoE switch via a PoE cable. The switch then connects to the building's Internet Router, which handles traffic to the Building Management System (BMS) (and other BACnet systems) and the Internet.
2. Bulk Configuration assistance from Kaiterra requires Internet connectivity. If Internet access is blocked or requires a manually configured Static IP, then each sensor must be configured individually.

7. Device Configuration

Individual Configuration

Individual configuration is required if the devices are on a localized network with no connection to the Internet, or require a manual Static IP Network Configuration.

1. Open the Kaiterra Configuration App on your smartphone and log in to your account.
2. Locate your building, then select “Add Device” → “Add Sensedge Mini”.
3. Turn the Sensedge Mini on by moving the power switch from “OFF” to “ON.” If the device is already powered on, power cycle it by switching to “OFF” for 10 seconds, then back to “ON.” The device will now broadcast a Wi-Fi Access Point (AP) signal.
4. Connect to the device’s Wi-Fi AP by selecting the network that starts with “Kaiterra”. After connecting successfully, press the “I’ve done all this” button. The device’s “Device Details” page will then appear.

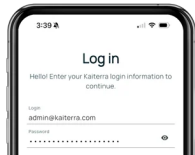

Sensedge Mini

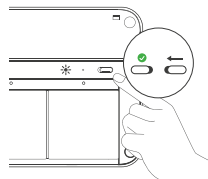

Instructions

1. Remove front panel from the device.
2. Power device on.
3. Open your network settings.
4. Connect with Wi-Fi network that starts with “Kaiterra”.

I've done all this

5. Press the “Configure” button to access and set all available Sensedge Mini settings, including Network Connection Type (Automatic DHCP or Static IP), Secondary MQTT, BACnet, Modbus, and Custom NTP Server settings.

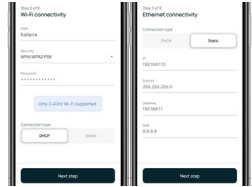

6. Once your configuration settings are saved, you'll be prompted to assign the device to a space in the building by selecting the device's floor and the corresponding space where it's installed.

Spaces can be created beforehand in the Kaiterra Data Platform; if the desired space does not yet exist, select “+ New” to add a new space.

Choose “Supply Duct” or “Return Duct” for the Space Type.

Assign a space

Calgary Office

Floor

1

Space

Kitchen



8. Bulk Configuration

Bulk configuration is recommended for large-scale installations, but it requires an active Internet connection. If bulk configuration is an option, it is best practice to perform an individual configuration on the first device. This confirms online connectivity and connection to the BMS (if applicable). Once the connection is confirmed, proceed with the bulk configuration method for the remaining devices.

1. Ensure that all Sensedge Duct devices are plugged in (via PoE) and powered on.
2. Record the following information for each device.
([Download this template](#))

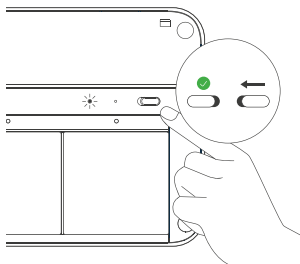

Field	Example	Notes
Building Code	123w	
Floor Code	Floor 01	
Space Code	01-CONFA	
Space Name	Floor 1 Conference Room A	
Space Type	Conference Room	
Device Name	123w-01-VG12345678-ConfA	
Device UDID	00000000-c0de-1234-5678-abcd1234c0de	
Device Serial Number	VG12345678	

Wi-Fi MAC Address	44-EF-BF-08-C9-A4	If required for network connectivity
Ethernet MAC Address	AE-98-76-54-32-10	If required for network connectivity
External Space ID	serraview:123456	If integrating with an external mapping ID
BACnet ID	12345	If configuring for BACnet connectivity
BACnet Port	47808	If configuring for BACnet connectivity

3. Share the recorded device information with your Kaiterra Customer Success Manager. (See the Troubleshooting section for contact information.)

Upon reception, this data will be used to upload devices to the Kaiterra Data Platform and bulk configure any remaining settings (e.g., BACnet ID). This process will be completed within two to five business days. If completion is delayed past five business days, please contact your Customer Success Manager.

9. Troubleshooting

For installation, configuration, and technical troubleshooting inquiries, contact your Customer Success Manager or directly email our support channel at support@kaiterra.com.